

Gladesville

7/12 Pearson Street



\$345 per week

2 Weeks free rent - Boutique one bedder

2 Weeks free rent - Apply now!

Located on the first floor of a well maintained boutique building is this sun-filled one bedroom apartment. Situated within close proximity to CBD transport and only a moments stroll to Glades Bay Park, 24-hour gym and main street eateries.

- One generously sized bedroom with built-in robe & ceiling fan
- Open plan living with laminate timber flooring opens to balcony
- Tidy kitchen with electric cooking appliances
- Modern ensuite bathroom
- Fly screens & roller blinds on all windows & doors
- Separate laundry on ground floor with additional storage
- Off street parking for one car

2 Weeks free rent* subject to terms and conditions



ADDITIONAL DETAIL

Type

Apartment

Kyla Penaar
0405 614 847
kyla@ch.com.au

Marija Marinkovic
0424 620 004
marija@ch.com.au

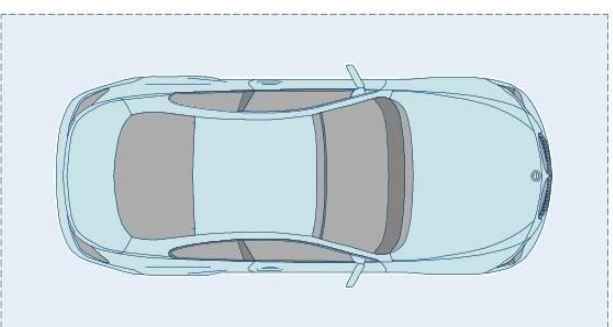
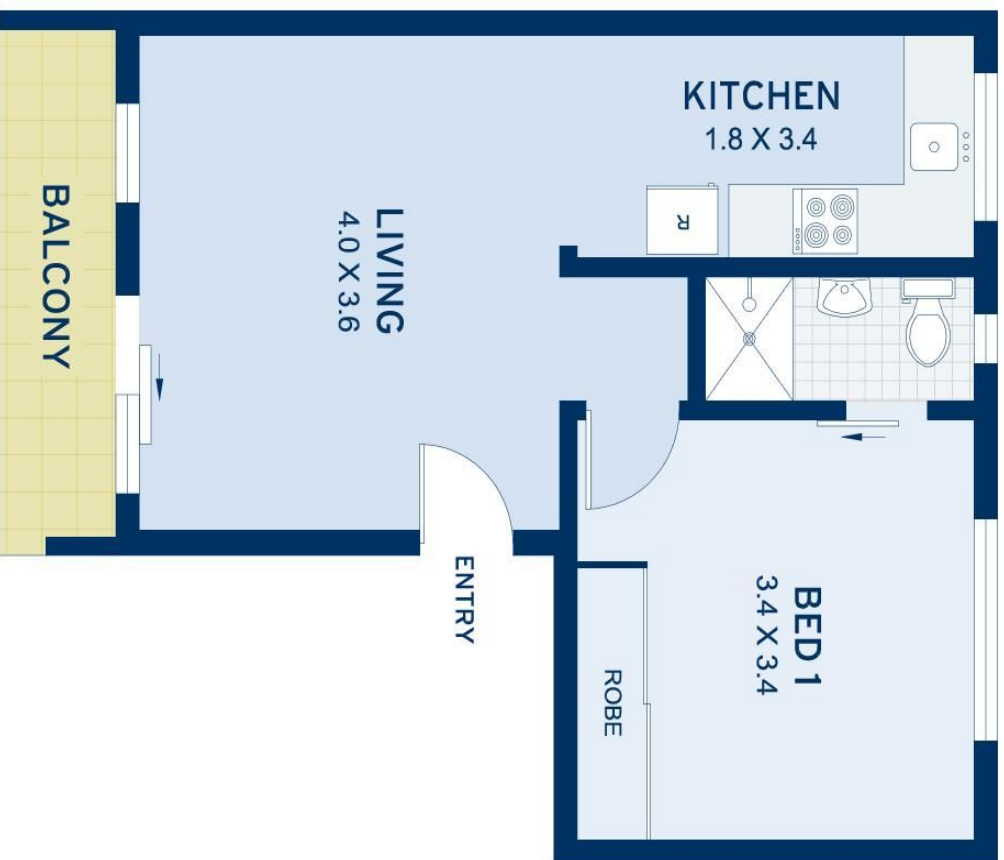

CARSPACE



Gladesville
7/12 Pearson Street

DISCLAIMER: This information has been prepared as a guide only. The vendor and the real estate agent, Balmain Real Estate Pty Ltd and/or Balmain Estate Agency Pty Ltd (trading as Cobden & Hayson Balmain), make no warranties as to its accuracy and all interested parties must rely on their own enquiries.

cobden & hayson